



FORMATURA
INIEZIONE
POLIMERI

FE/CE



FIP

FE

FE

-
-
- 25) • : DN40 DN200 (DIN3202 K2 ISO5752
- 16 20°
-
-
-
- EPDM, FPM NBR
-
- FIP
-
-
- 2

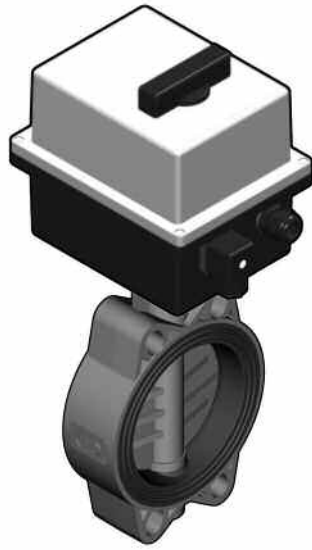

d	()	
DN	()	
R		
PN		
	,	20°
g		
U		
s	()	
SDR	d/s	
U-PVC		
PP-H		
PVC-C		
PVDF	()	
EPDM	-	-
FPM		
PTFE		
PE		

1

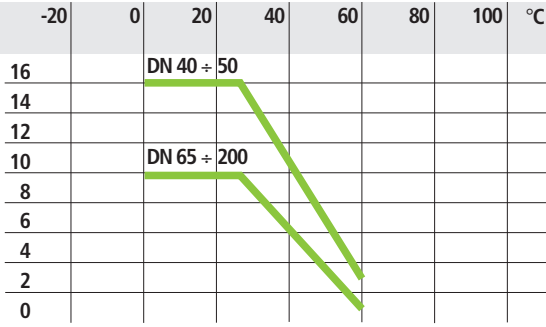

2

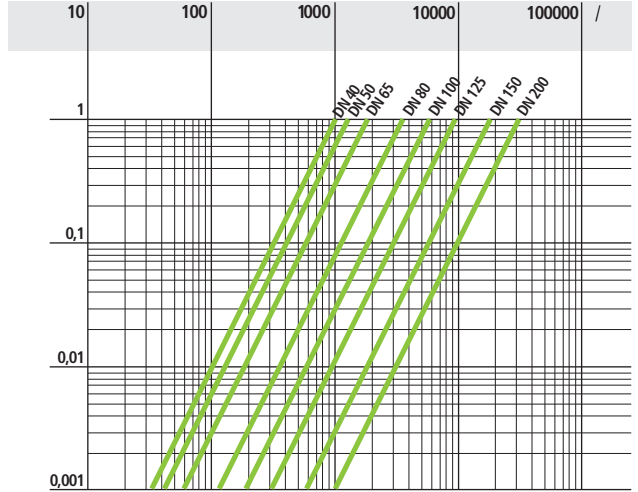

3

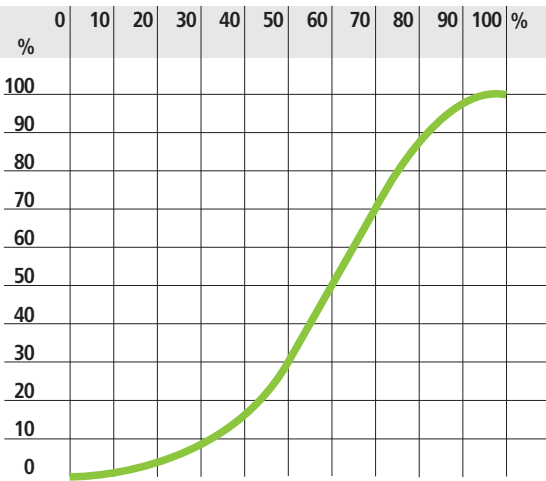

4

d	50	63	75	90	110	140	160	225
DN	40	50	65	80	100	125	150	200
k_{v100}	1000	1285	1700	3550	5900	9850	18700	30500

1

(25)

2

3

4

k_{v100} - / $\ddot{A}_p = 1$ 20°

FE

: ISO 5752

25 DIN 3202 K2.

- DIN 2501, ISO DIS 9624, UNI 2223
- BS 10 D/E
- ASA B16.5 150
- JIS 2212 K10 (DN200), JIS 2212 K5 (DN50)

FEOV/CE

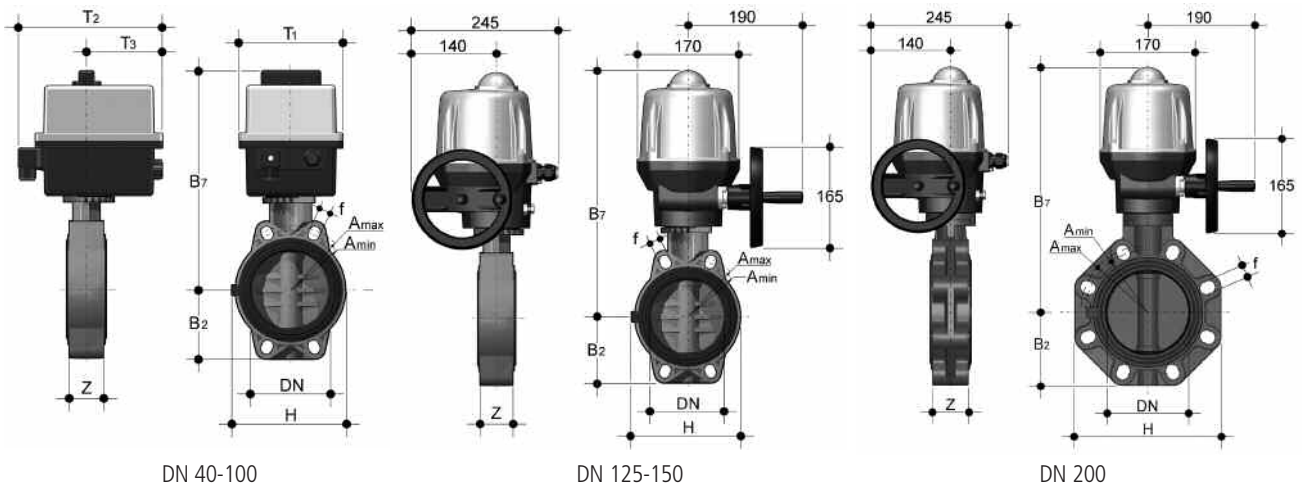

d	DN	PN	B ₂	B ₇	T ₁	T ₂	T ₃	H	Z	A _{min}	A _{max}	f	g	U
50	40	16	60	253	92	189	91	132	33	93	109	19	2074	4
63	50	16	70	259	92	189	91	147	43	108	124	19	2254	4
75	65	10	80	266	92	189	91	165	46	128	144	19	2480	4
90	80	10	93	308	128	204	95,5	130	49	145	159	19	4000	4
110	100	10	105	322	128	204	95,5	150	56	165	190	19	4350	4
*125	125	10	121	425	-	-	-	185	64	204	215	23	8100	4
140	125	10	121	425	-	-	-	185	64	204	215	23	8100	4
160	150	10	132	438	-	-	-	210	70	230	242	23	8800	4
**200	200	10	161	485	-	-	-	325	71	280	298	23	11560	8
225	200	10	161	485	-	-	-	325	71	280	298	23	11560	8

*FEOV d140

** FEOV d225

 - d125
 - d225



FE/CE

FE/CE LUG

: DN 40-200
: ISO-DIN
PN: 6-4 20° ()

FEOV (LUG).

FE LUG

FEOV/CE LUG

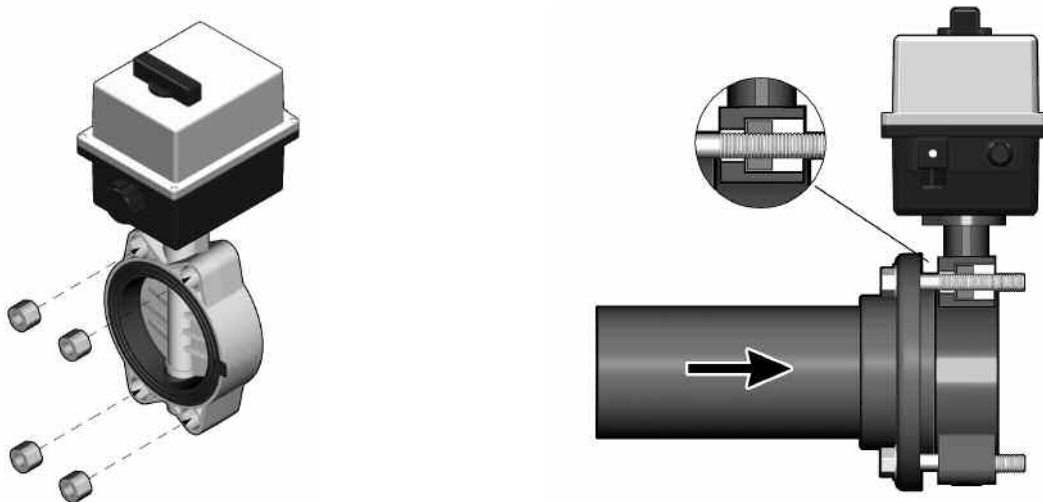

d	50	63	75	90	110	140	160	225
DN	40	50	65	80	100	125	150	200
PN (1)	16	16	10	10	10	10	10	10
PN LUG (2)	6	6	6	6	6	4	4	4

(1)

(2)



: -10° - +55°

:
 DIN 43650 3P+T (DN 40-100)
 ISO M20 (DN125-200)
 ISO M20 (DN125-200)

-
-
- 2
-

- 4-20 0-10 ()
-
-
- 0,1-1-5-10
- 4-20
- IP67 ATEX EEx

	DN40-65			DN80-100			DN125-150		DN200	
	DC	AC/DC	AC	DC	AC/DC	AC	AC/DC	AC	AC/DC	AC
	12V*	24V	100-240V	12V*	24V	100-240V	24V	100-240V	24V	100-240V
	26W	11W	15W	26W	15W	15W	85W	85W	85W	85W
	8s	20s	20s	20s	60s	60s	30s	30s	50s	50s
CEI34	30%	30%	50%	30%	50%	50%	50%	50%	50%	50%
	IP65	IP65	IP65	IP65	IP65	IP65	IP67	IP67	IP67	IP67

*

FE/CE DN 40-65

Трёхпозиционное регулирование

Отсечной режим

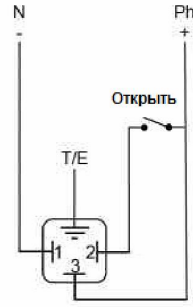
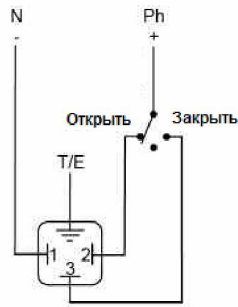
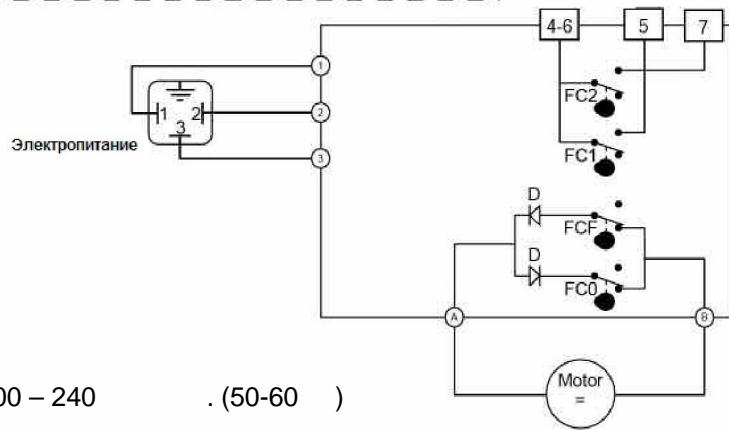
 Подключения
заказчика

 Дополнительные
концевые выключатели

100 – 240

(50-60)

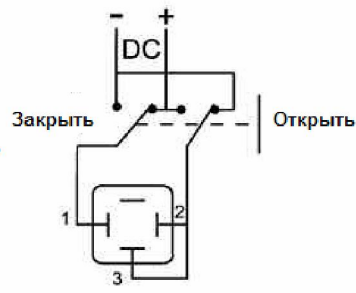
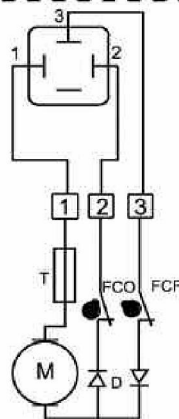
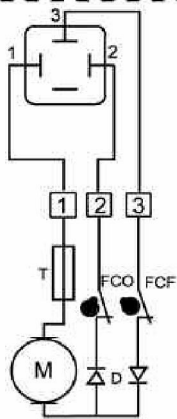
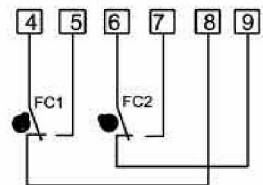
Электропитание

 Подключения
заказчика

 Электропроводка
привода

 Дополнительные
концевые выключатели

24

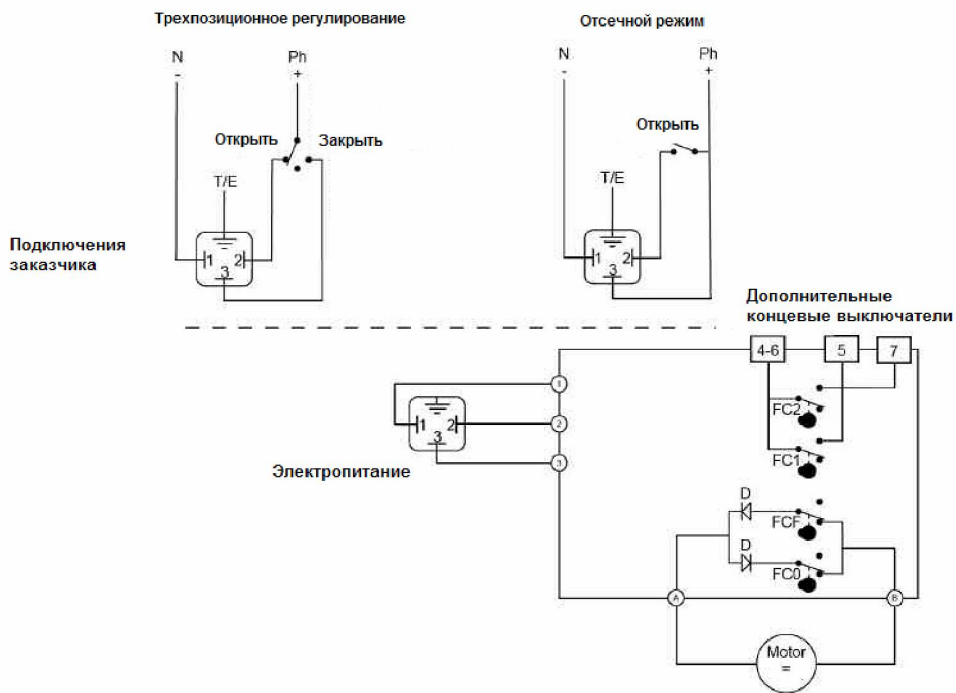
(50) /

FE/CE DN 80-100



24, 100-240 . (50-60)
24 .

FE/CE DN 125-200

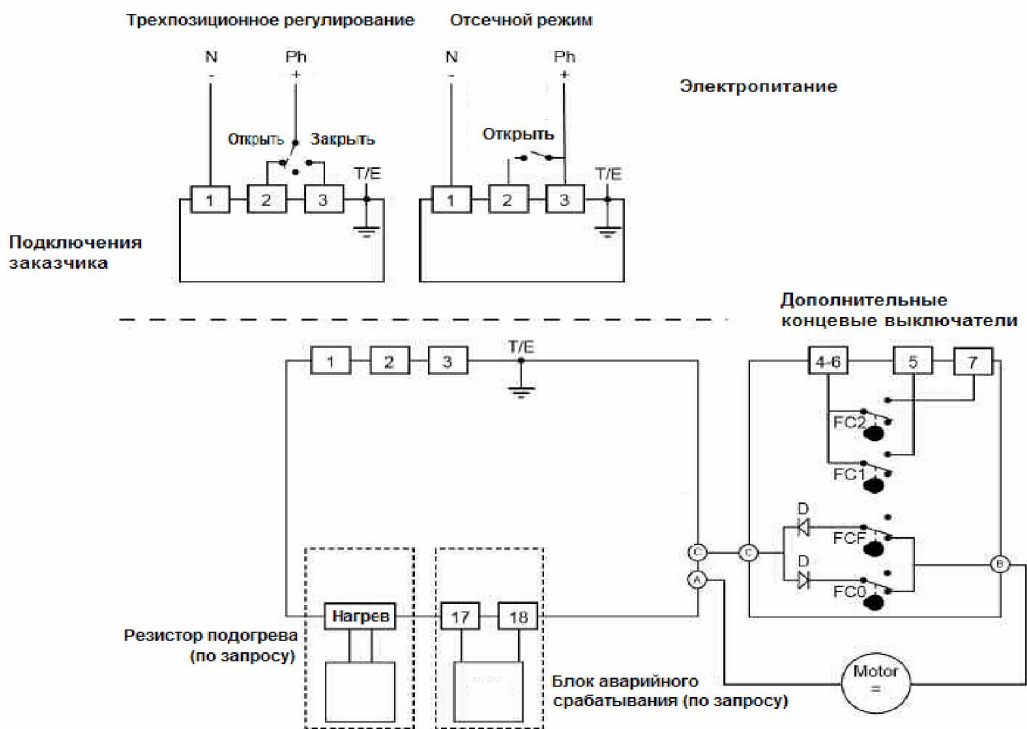

24, 100-240 . (50-60)
24 .

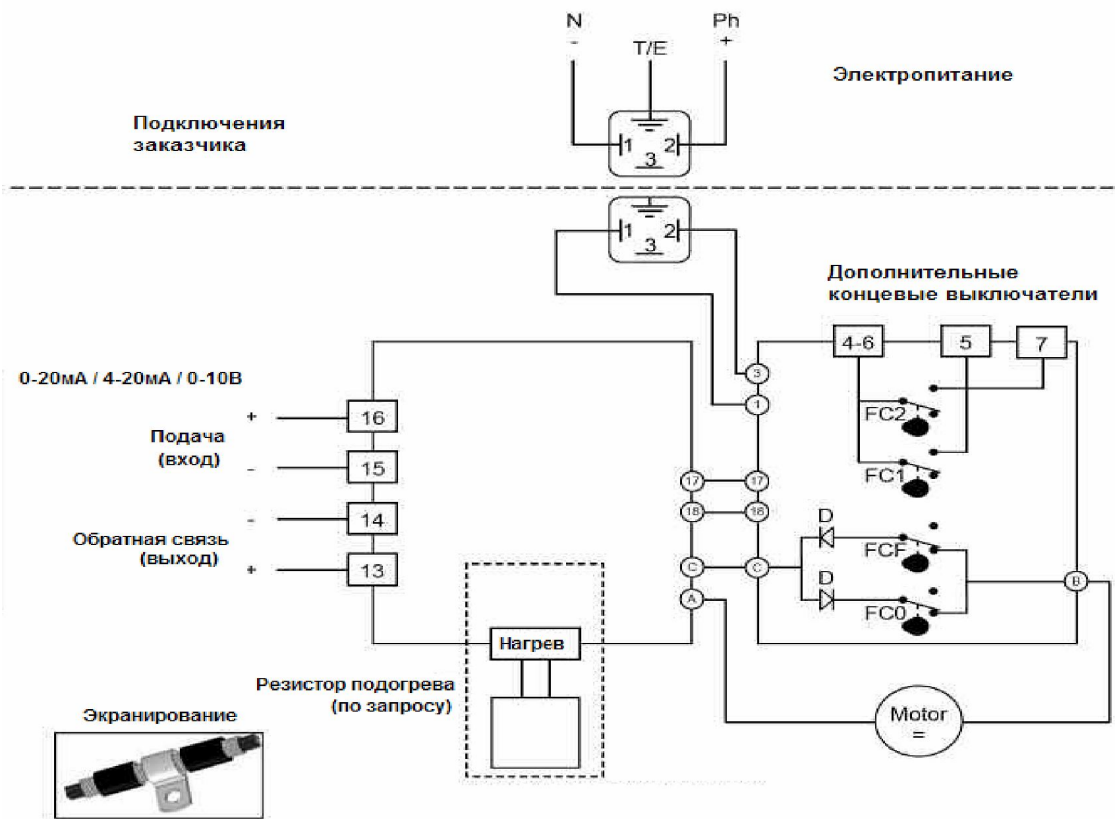
DN 40-100 RE (0/4-20 mA - 0-10V)

4-20 / 0-10
24, 100-240 . (50-60)
24 .

DN 125-200 RE (0/4-20 mA - 0-10V)

Подключения заказчика

Только 100-240 В перем. тока

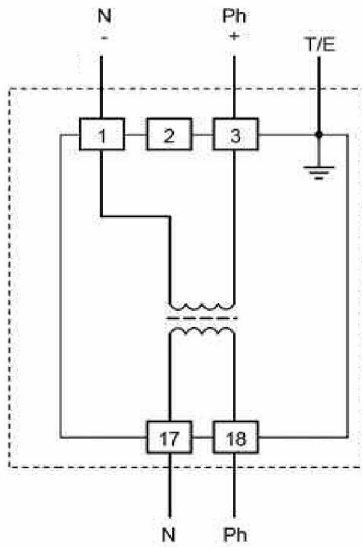
Электропитание

Только 24 В пост. тока

0-20мА / 4-20мА / 0-10В

Подача (вход)
+ — 16
- — 15

Обратная связь (выход)
- — 14
+ — 13

Экранирование

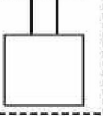
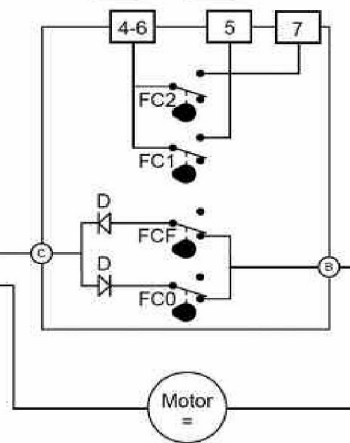

Резистор подогрева (по запросу)

Дополнительные концевые выключатели

24, 100-240 / 4-20 / 0-10
24 . (50-60)

FS BLOCK NC (DN 40-65)

Аварийное закрытие

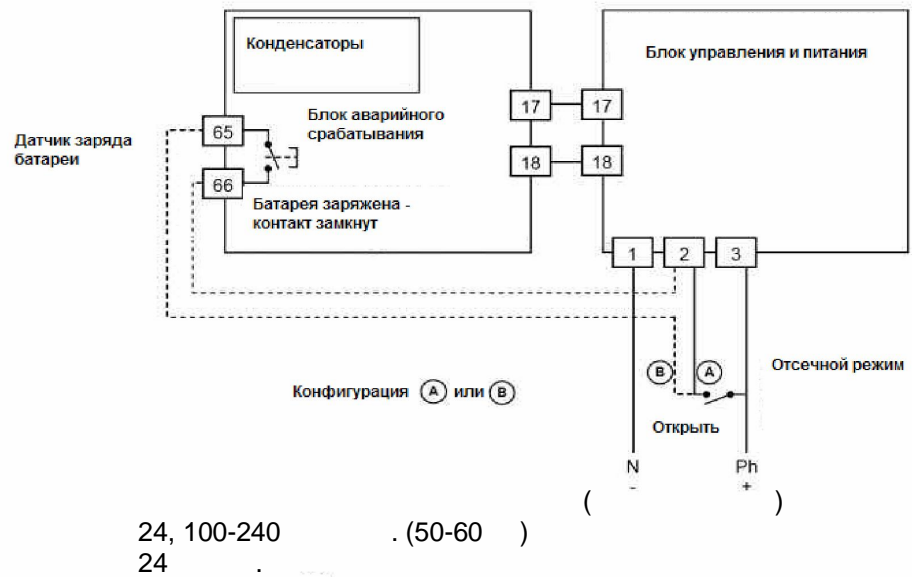

FS BLOCK NC (DN 80-200)

Аварийное закрытие

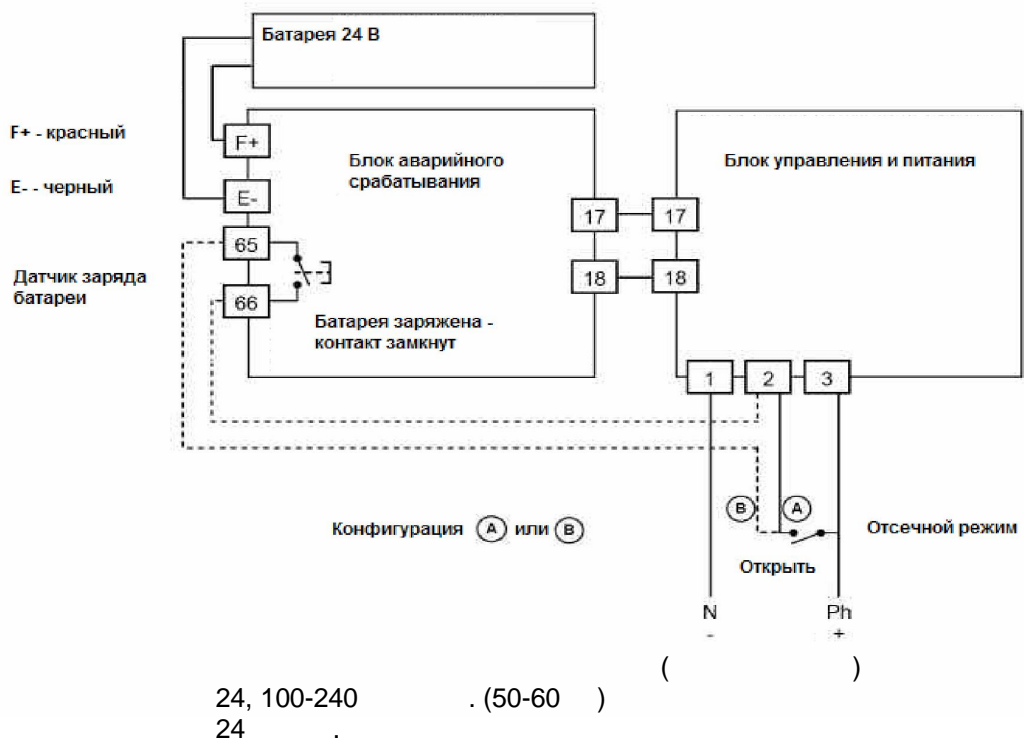

R1 (0,1 K) - R2 (1 K) - R3 (5 K) - R4 (10 K)

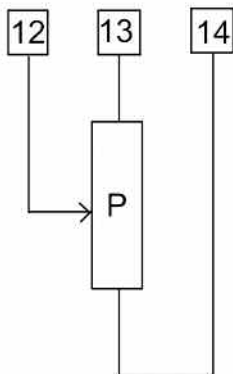

0,1-1-5-10

TR 4-20 mA

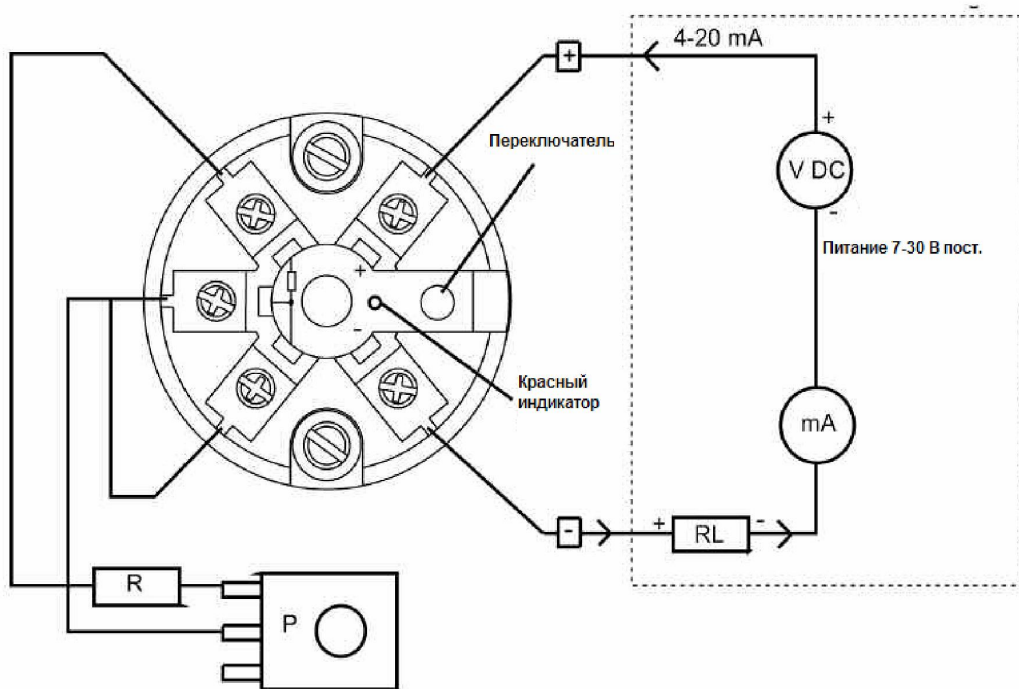

4-20

FE

(. I min) '

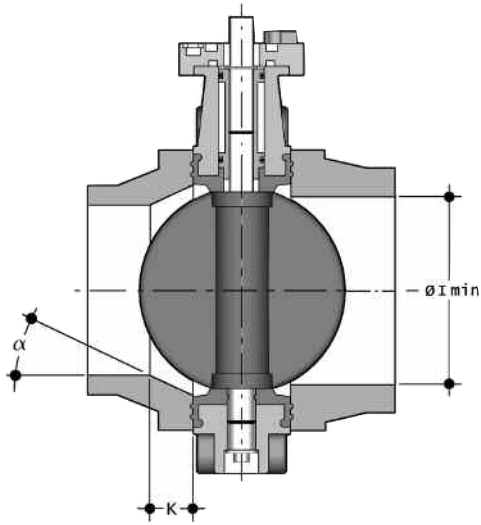

d	DN	I min.
50	40	25
63	50	28
75	65	47
90	80	64
110	100	84
140	125	108
160	150	134
225	200	187

B

Tab. B

d	DN	50	63	75	90	110	125	140	160	200	225
		40	50	65	80	100	110	125	150	200	200
50	40										
63	50										
75	65										
90	80										
110	100										
140	125						*				
160	150										
225	200									**	

DIM8063-T4

* d140 DN125 - d125 DM125 FE d140 DN125

** d225 DN200 - d200 DM200 FE d225 DN200

PP-PE
K a
SDR

Tab. C

FE	d	DN	50	63	75	90	110	125	140	160	180	200	225
			40	50	65	80	100	110	125	150	150	200	200
	50	40											
	63	50											
	75	65											
	90	80											
	110	100											
	140	125											
	160	150											
	225	200											
SDR		17/17,6										k=35 a=20°	
		11								k=35 a=20°		k=35 a=25°	k=40 a=15°
						k=10 a=35°	k=15 a=35°		k=20 a=30°	k=30 a=30°	k=15 a=35°	k=40 a=20°	k=35 a=30°

/ DIN16962/16963

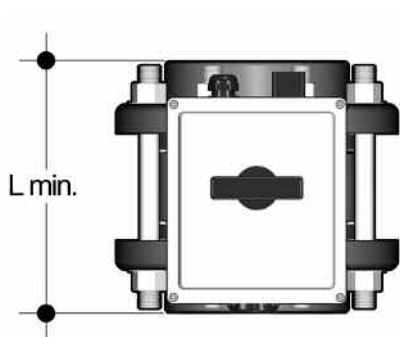

d	DN	Lmin	*Nm
50	40	M16x150	9
63	50	M16x150	12
75	65	M16x170	15
90	80	M16x180	18
110	100	M16x180	20
125*-140	125	M16x210	35
160	150	M20x240	40
200**-225	200	M20x260	55

*

1/5xPN (20°)

- 1.
- 2.
- 3.
- 4.
- 5.

EPDM.

6.

-
-
-
-
-

45°

.1.

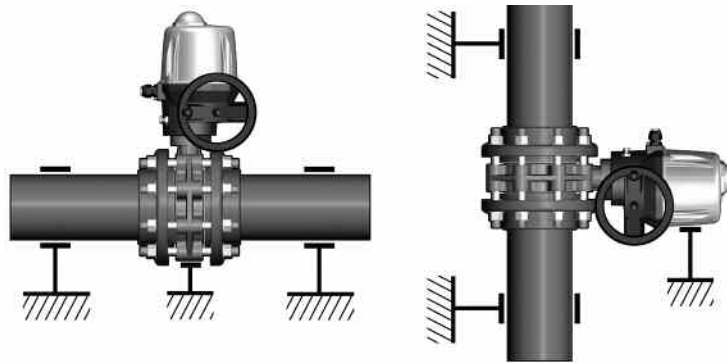

Fig. 1

(DN 40-200)

1.		(4)	(2)	(3)
2.	(1)			
3.		(18)	(17)	(16)
4.	(5)	(14)		
5.		(15)	(11)	
6.		(8)	(10)	
7.	6		(6)	(7)

(DN 40-200)

1.		(15)	(11)	
2.			(6 7)	(5)
3.		(9)	(10),	
4.		(8)	(12),	(13)
4.	(14).		(15)	
5.				
6.	(17)		(16)	(18)
7.		(1)		
8.	(2)		(3)	(4)

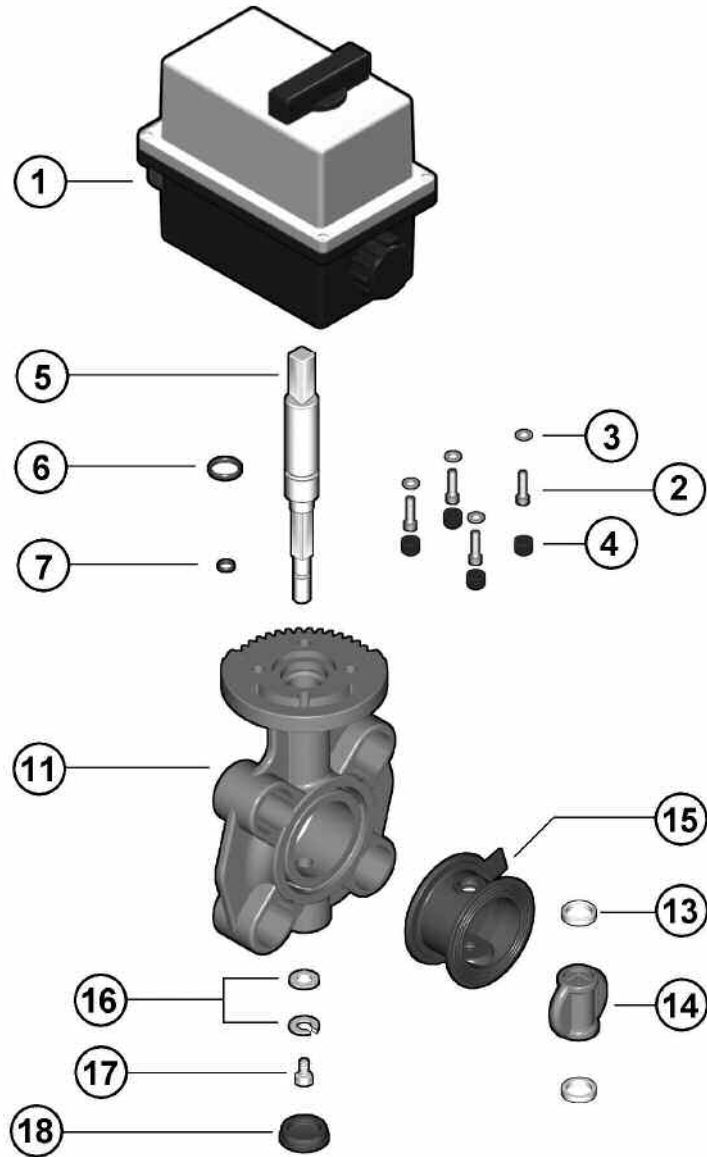

DN 40 ÷ 50

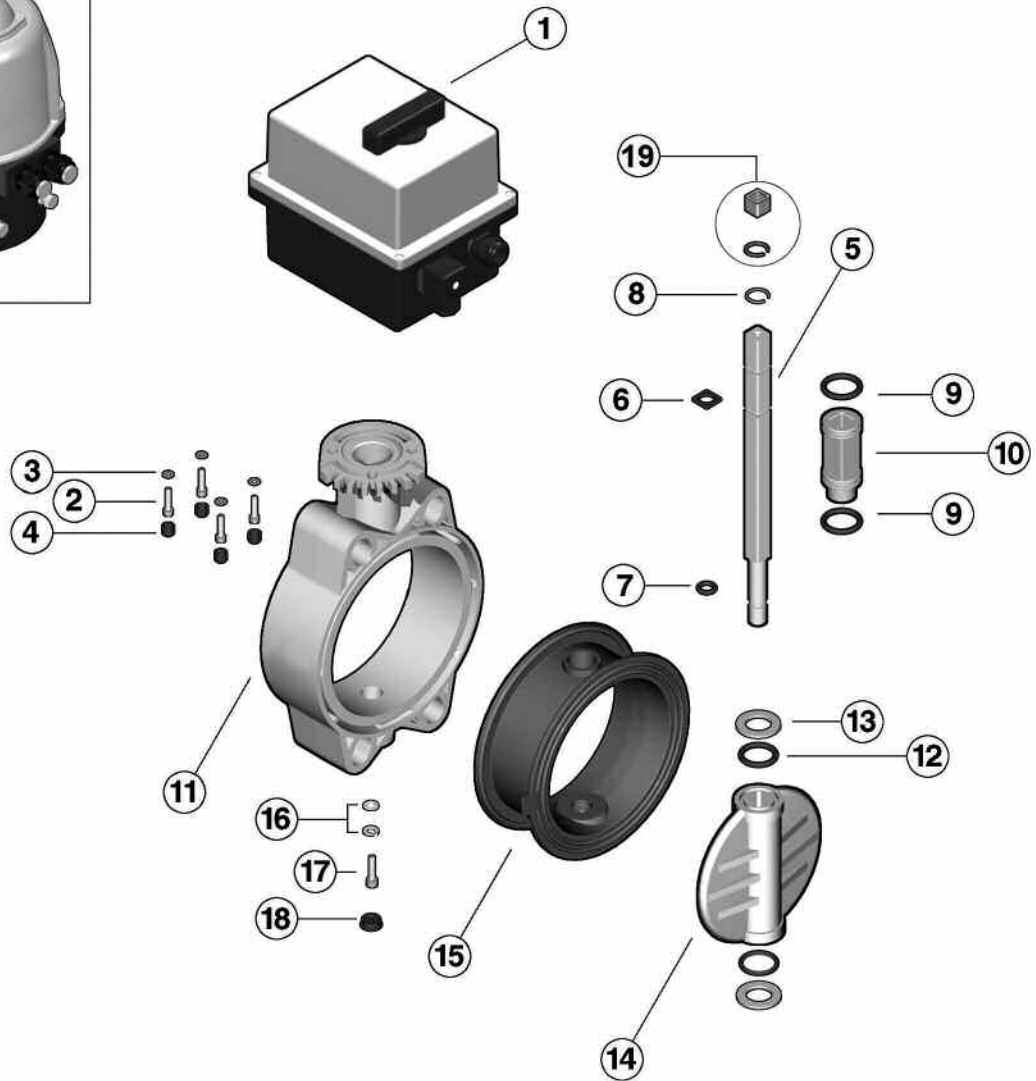

DN 65 ÷ 200

1		ABS	1
2			4
3			4
4		PE	4
5			1
6		EPDM FPM	1
7		EPDM FPM	1
8			2
9		EPDM FPM	2
10			1
11			1
12		EPDM FPM	2
13		PTFE	2
14			1
15		EPDM FPM	1
16			4
17			4
18		PE	1
19			1